

Chassis By

**CHARLATTE**  
**G S E**  
FAYAT GROUP

Bodywork By

**PHOENIX**  
METAL PRODUCTS, INC.

# HLM15

## Aerial Platform



Utilizing the DC3 chassis, the Hylifter HLM-15 aerial platform and airport mobile maintenance platform is an economic self contained hydraulic platform that provides 15' vertical height and 20' of working height. The HLM-15 includes standard features such as round handrails, fail safe pump control relay, cylinder locking valve, low pressure-over sized cylinder corrosion proof rollers and maintenance support stands..

DESIGN, PERFORMANCE, RELIABILITY, SAFETY, ENDURANCE AND PRODUCT SUPPORT MAKE OUR PRODUCTS FAMOUS WORLDWIDE

# HLM15

## TECHNICAL CHARACTERISTICS

### CAPACITY:

- 600 Lbs.

### STRUCTURE:

- Scissor Arms are made from 2 X 4 X 3/16 Structural Steel Tubing
- Precision Machined Bushings
- 100,000 PSI Stress Proof Pivot Shafts
- Corrosion Proof Rollers
- 1" Round Handrails

### PLATFORM

- 94" L X 60" W Standard
- Formed Floor Panels
- All Welded Construction
- Pockets for Handrails
- 1" Wide Radius Handrails

### HYDRAULIC:

- Self Contained 12V DC Power Unit
- 3 Stage Telescoping Hydraulic Cylinder
- Low Pressure Hydraulic System
- Safety Holding Valve
- Skydrol Resistant Hydraulic Hoses

### ELECTRICAL:

- Upper and Lower Controls
- Lower Control Override
- Emergency Electrical Letdown
- Weather Tight Control Boxes
- Fail Safe Pump Relay
- Emergency Stop

### OPTIONS:

- Pendant Controls
- Platform Width 48" X 54"
- Tool Boxes
- Access Step
- Work Lights
- Platform Rubber Bumpers
- Lift Gate
- Skydrol Resistant Rubber Floor Covering
- Manual, Electric, & Hydraulic Stabilizers
- Galvanized

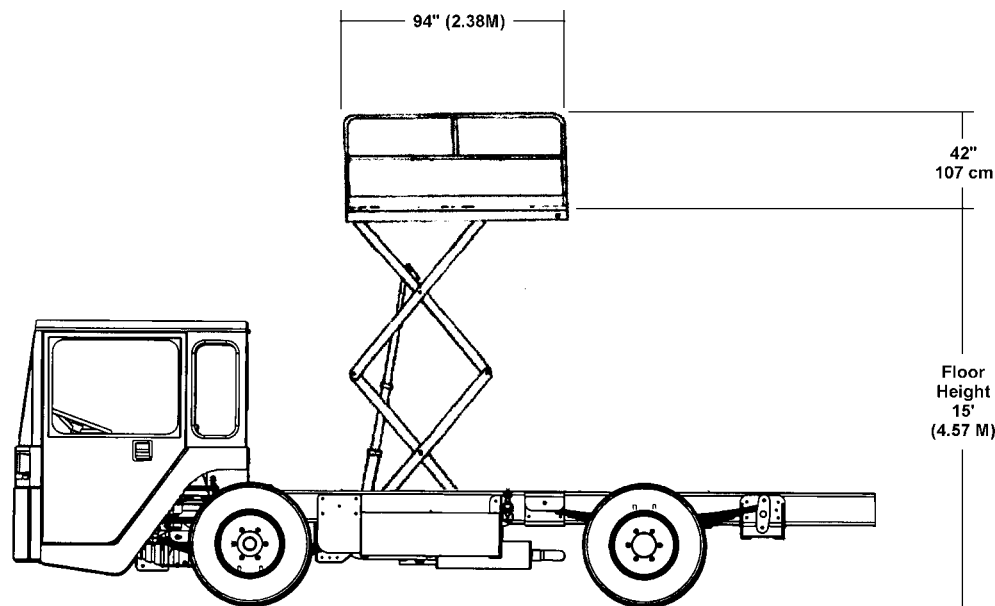

These descriptions are given as an indication only and do not represent a commitment

[www.charlatte.com](http://www.charlatte.com)

**CHARLATTE**  
**G S E**  
FAYAT GROUP

Charlotte America  
P.O. Box 968  
600 Mountain Lane  
Bluefield, VA 24605  
Phone: (276) 326-1510  
Fax: (276) 326-1602  
Spare Parts Fax: (276) 326-3898  
e-mail: [equipmentsales@charlatteus.com](mailto:equipmentsales@charlatteus.com)

Charlotte Manutention  
Z.I. – Route du Boutoir  
89210 Briennon sur Armancon France  
Phone: (33) 386 43 01 30  
Fax: (33) 386 43 04 66  
Email: [manutention@charlatte.fr](mailto:manutention@charlatte.fr)

Charlotte United Kingdom  
2 Hall Farm Cottages  
Stanton Lane  
Potters Marston  
Leicester – LE9 3JR  
Phone: (44) 01 1455 272 212  
Fax: (44) 01 1455 274 393  
Mobile: (44) 07 767 230 149  
e-mail: [uksales@charlatteuk.com](mailto:uksales@charlatteuk.com)