

Chassis By

CHARLATTE
G S E
FAYAT GROUP

PNX-TL600

Lavatory Service
Truck

Bodywork By

PHOENIX
METAL PRODUCTS, INC.



The Charlotte PNX-TL600 lavatory service truck is designed to service all sizes of commercial aircraft. A manlift option is required to service wide body aircraft. The unit uses a two tank system for lavatory servicing. The waste tank and flush tank are separate components fabricated from 304 stainless steel and are baffled in both directions. A hinged cleanout cover is provided on the waste tank for easy access to the dump valve to remove impediments. The waste tank has a tray to store the waste hose and prevent spillage of waste onto the top of the unit. The flush system uses an electrically actuated clutch to provide power for the hydraulic system that powers a bronze gear drive water pump. The system is actuated by mechanical switches at the service end of the vehicle.

DESIGN, PERFORMANCE, RELIABILITY, SAFETY, ENDURANCE AND PRODUCT SUPPORT MAKE OUR PRODUCTS FAMOUS WORLDWIDE

PNX-TL600

TECHNICAL CHARACTERISTICS

TANKS:

- Waste Tank 360 Gallons
- Flush Tank 240 Gallons
- Tanks Baffled in Both Directions
- All Tank Materials are Stainless Steel
- All Fittings are Stainless Steel
- 4" Ball Dump Valve
- Fill Gauge Flush Tank
- Clean Out Hinged Inspection Cover
- Waste Hose Stowage Tray w/Stowage
- Nipple
- Insect Protection, Vented Tanks
- 1 'A" Flush Tank Drain Valve

TANK PLATFORM:

- Heavy Gauge 2"x 3" Structural Steel Tube Frame
- Galvaneal Steel Bottom & Sides
- 1/2" Exterior Grade Plywood Tank Cushion
- Rear Step Bumper of Galvanized Steel Gripstrut
- Removable Galvaneal Steel Panels

TANK PLATFORM CON'T:

- Access Doors with Bolt On Stainless Steel Hinges
- Aluminum Tread Plate Top Deck
- Aluminum Rear Splash Guards
- Rubber Rear Top Bumpers

AIRCRAFT SERVICES:

- Electrically Actuated Engine Driven Clutch to Provide Power for Hydraulic System
- Bronze Direct Drive Water Pump
- Stainless Steel Hydraulic Tank w/Filter
- Pumps 20GPM@40PSI
- 1" Quick Coupling
- 25' Reinforced PVC Hose
- Spring Rewind Hose Reel
- 4" Straight Locking Coupling
- Automatic Flush Hose Drain Back
- 60 Micron Filter
- Rear Service Spot Light
- Resetable Meter
- 12' 4" Reinforced Waste Hose
- Rear Indicator Flag
- Interlock for Pumping in Park
- Waste Inlet Swivel

OPTIONS:

- Full Insulation-2" Bottom, 2" Top & 1"
- Sides
- Flush Tank Immersion Heater
- Rear Compartment Hot Water Space Heater
- 110 Volt Space Heater
- 110 Volt Dump Valve Heater
- Wide Body Personnel Lift
- Wye Coupling
- Closed Dump System
- Electric Pump
- Dual Waste Hose Wide Body/Narrow Body
- Safety Chocks w/holders
- Back Up Alarm
- Amber Flashing Beacon
- Gripstrut Top Deck
- Recessed Top Deck Access Ladder
- Grill and Body Guards
- Transmission Safety Interlock (Lock in Park)
- Hand Brake Interlock
- Hour Meter
- Larger Tank Capacity
- All Stainless Steel Construction

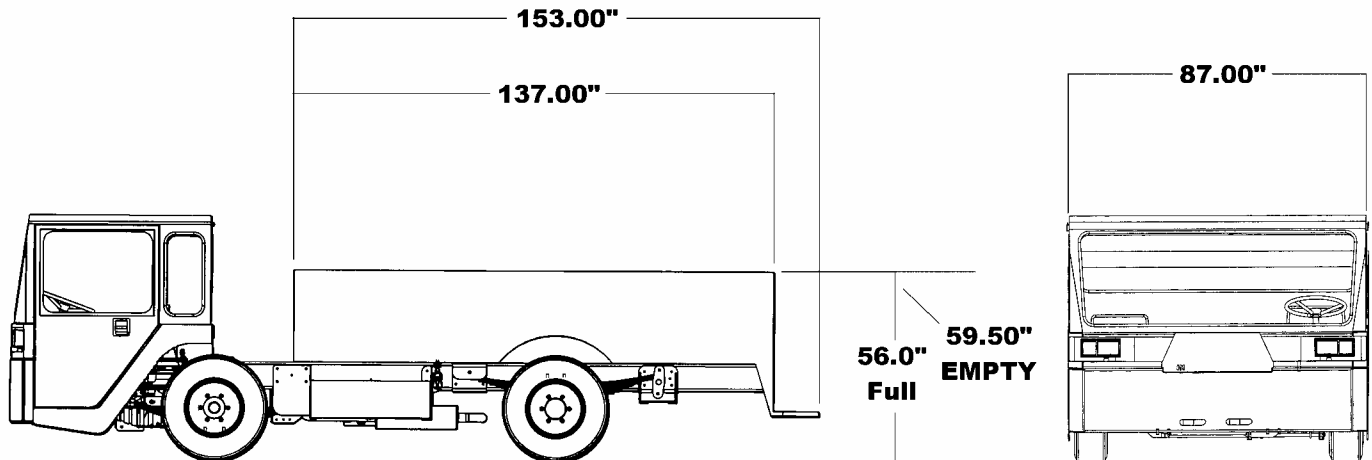

These descriptions are given as an indication only and do not represent a commitment

CHARLATTE
G S E
FAYAT GROUP

www.charlatte.com

Charlatte America
P.O. Box 968
600 Mountain Lane
Bluefield, VA 24605
Phone: (276) 326-1510
Fax: (276) 326-1602
Spare Parts Fax: (276) 326-3898
e-mail: equipmentsales@charlatteus.com

Charlatte Manutention
Z.I. – Route du Boutoir
89210 Brienon sur Armancon France
Phone: (33) 386 43 01 30
Fax: (33) 386 43 04 66
Email: manutention@charlatte.fr

Charlatte United Kingdom
The Studio
2 Hall Farm Cottages
Stanton Lane
Potters Marston
Leicester – LE9 3JR
Phone: (44) 01 1455 272 212
Fax: (44) 01 1455 274 393
Mobile: (44) 07 767 230 149
e-mail: sales@charlatteuk.com